



DC-AD2X
The World's Best VGA to DVI Converter

Owner's Manual

Dtrovision LLC
9A Bergen Turnpike
Little Ferry, NJ 07643
USA
Tel: +1.201.488.3232
Fax: +1.201.621.6118
Email: support@dtrovision.com
www.dtrovision.com

For order support, please contact your local dealer.
For technical support, please contact us at support@dtrovision.com

1. Revision History

Rev. No.	Date	Comment
----------	------	---------

2. CONTENTS

1. Revision Sheet
2. Description
3. General Specification
4. Environmental and Reliability Specifications
 - 4.1 Operating Conditions
 - 4.2 Transportation Conditions
 - 4.3 Storage Conditions
 - 4.4 Reliability Specifications
5. Electrical Specification
 - 5.1 Input Signal Characteristics
 - 5.2 Output Signal Characteristics
 - 5.3 Power Management
 - 5.4 Connector Pin Assignment
 - 5.5.1 J1 : DC Input
 - 5.5.2 J4 : Analog RGB Input
 - 5.5.3 J5 : DVI-D Output
 - 5.5.4 J6 : Analog RGB Output
6. Mechanical Specification
 - 6.1 Dimensions
7. Operation Guide
 - 7.1 Installation
 - 7.2 OSD Adjustment
 - 7.2.1 Key Name and Function
 - 7.2.2 OSD Adjustment
8. Standard Timing Chart

2. Description

DC-AD2X Controller board is analog RGB interface board for TFT LCD Monitor that is providing high quality screen image.

This controller board supports from VGA to UXGA resolution at 60Hz~85Hz refresh rate with expanding to full screen image.

EG180SX is especially designed for the LCD Monitor which is supporting 1600x1200 @60hz high resolution.

3. General Specification

ITEM	DESCRIPTION	REMARKS
Model Name	DC-AD2X	
Input Signal	Analog RGB D-SUB	
Output Signal	DVI (TMDS) D-SUB	1600 X 1200 @ 60Hz Max
Resolution	Hf : 30 to 80 KHZ Vf : 60 to 85 HZ RGB : VGA / SVGA / XGA / SXGA / UXGA	640 X 480 @60Hz,75Hz 720 X 400 @70Hz 800 X 600 @60Hz,75Hz 1024 X 768 @60Hz,75Hz 1280 X 1024 @60Hz 1600 x 1200 @60Hz
Receptacle	DC Power Jack D_SUB DVI	
Image Scaler	PW131A	Pixelworks
Power Consumption	9W Max	DC +5V / 1.2A
Board Demension	140 x 95 mm	
User Controls	6 Buttons Control	
Plug & Play	DDC2B	VESA

4. Environmental and Reliability Specifications

4.1 Operating Conditions

4.1.1 Temperature : 10°C ~ 40°C

4.1.2 Humidity : 10% ~ 80%, non-condensing

4.1.3 Altitude : maximum 3,000m

4.2 Transportation Conditions

4.2.1 Temperature : -25°C ~ 60°C

4.2.2 Humidity : 5% ~ 95%, non-condensing

4.2.3 Altitude : maximum 15,000m

4.3 Storage Conditions

4.3.1 Temperature : -20°C ~ 45°C

4.3.2 Humidity : 5% ~ 95%, non-condensing

4.3.3 Altitude : maximum 3,000m

4.4 Reliability Specifications

4.4.1 MTBF : more than 50,000 hours at 90% confidence level

4.4.2 Reliability specification and items : refer to “Specification of reliability test for LCD monitor”

5. Electrical Specification

5.1 Input Signal Characteristics

Input Signal	Description	Unit	Min	Typical	Max	Remarks
DC input	DC Voltage	VDC	4.5	5	5.5	
	Power Consumption	Watts	2.0	3.0	6.0	
15Pin D-Sub	Video	Vp-p		0.714(1.0)		75Ω Terminated
	Sync Voltage	Vp-p		5.0		
	Horizontal Frequency	Khz	30	-	80	Depends on Mode
	Vertical Frequency	Hz	60	-	85	Depends on Mode

5.2 Output Signal Characteristics

Output Signal	Description	Unit	Min	Typical	Input Signal	Remarks
TMDS Interface	Differential Output	mVp-p	450	510	570	
15Pin D-Sub	Video	Vp-p		0.714(1.0)		75Ω Terminated
	Sync Voltage	Vp-p		5.0		
	Horizontal Frequency	Khz	30	-	80	Depends on Mode
	Vertical Frequency	Hz	60	-	85	Depends on Mode

5.3 Power Management : VESA DPMS standard is applied for power management control.

Mode	HSync	VSync	Video signal	LED Indication	Power Consumption
On	Active	Active	Active	LED On	< 5 W
Stand-by	Inactive	Active	Blanked	Green Blink 1sec	< 3 W

Suspend	Active	Inactive	Blanked	Green Blink 1sec	
Off	Inactive	Inactive	Blanked	Green Blink 1sec	

5.4 Connector Pin Assignment

5.5.1 J1 : DC Input

Part No.	Pin No.	Description	Remarks
DC002	1	VCC(DC5V)	
	2	GND	
	3	GND	

5.5.2 J4 : Analog RGB Input

Part No.	Pin No.	Description	Remarks
DB15HD	1	RED	
	2	GREEN	
	3	BLUE	
	4	GND	
	5	GND(DDC-RETURN)	
	6	GND-RED	
	7	GND-GREEN	
	8	GND-BLUE	
	9	N.C	
	10	GND-SYNC	
	11	GND	
	12	DDC-DATA	
	13	H-SYNC	
	14	V-SYNC	
	15	DDC-CLOCK	

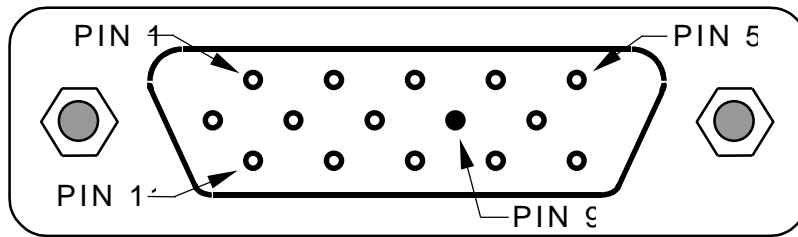

5.5.3 J5 : DVI-D Output

Part No.	Pin No.	Description	Remarks
SD74320-003 (MOLEX)	1	TMDS DATA 2M	
	2	TMDS DATA 2P	
	3	TMDS DATA 2/4 Shield	
	4	TMDS DATA 4M(N.C)	
	5	TMDS DATA 4P(N.C)	
	6	DDC Clock	
	7	DDC Data	
	8	N.C	
	9	TMDS DATA 1M	
	10	TMDS DATA 1P	
	11	TMDS DATA 1/3 Shield	
	12	TMDS DATA 3M(N.C)	
	13	TMDS DATA 3P(N.C)	
	14	5V	
	15	GND	
	16	Hot Plug Detect	
	17	TMDS DATA 0M	
	18	TMDS DATA 0P	
	19	TMDS DATA 0/5 Shield	
	20	TMDS DATA 5M(N.C)	
	21	TMDS DATA 5P(N.C)	
	22	TMDS DATA Clock Shield	
	23	TMDS Clock P	
	24	TMDS Clock M	

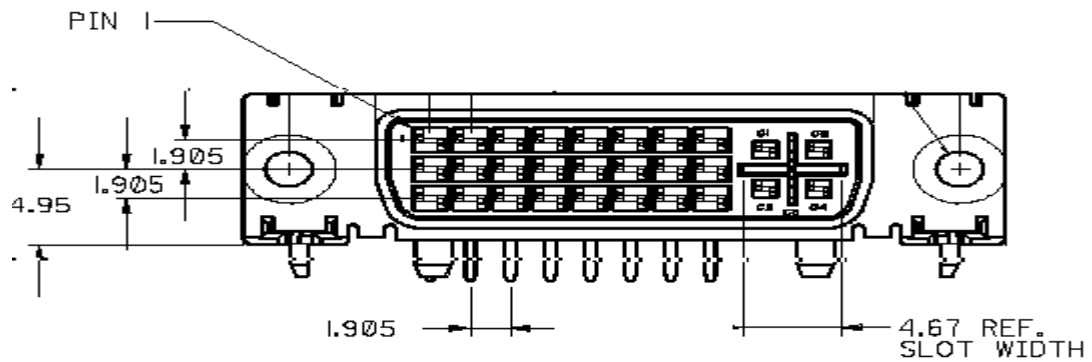

5.5.4 J6 : Analog RGB Output

Part No.	Pin No.	Description	Remarks
DB15HD	1	RED	
	2	GREEN	
	3	BLUE	
	4	GND	
	5	GND (DDC-RETURN)	
	6	GND-RED	
	7	GND-GREEN	
	8	GND-BLUE	
	9	N.C	
	10	GND-SYNC	
	11	GND	
	12	DDC-DATA	
	13	H-SYNC	
	14	V-SYNC	
	15	DDC-CLOCK	

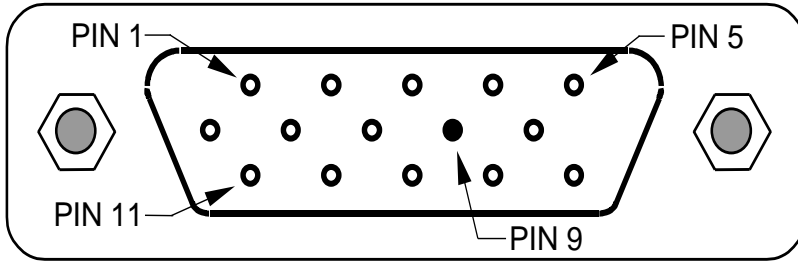

6. Mechanical Specification

6.1 Dimensions

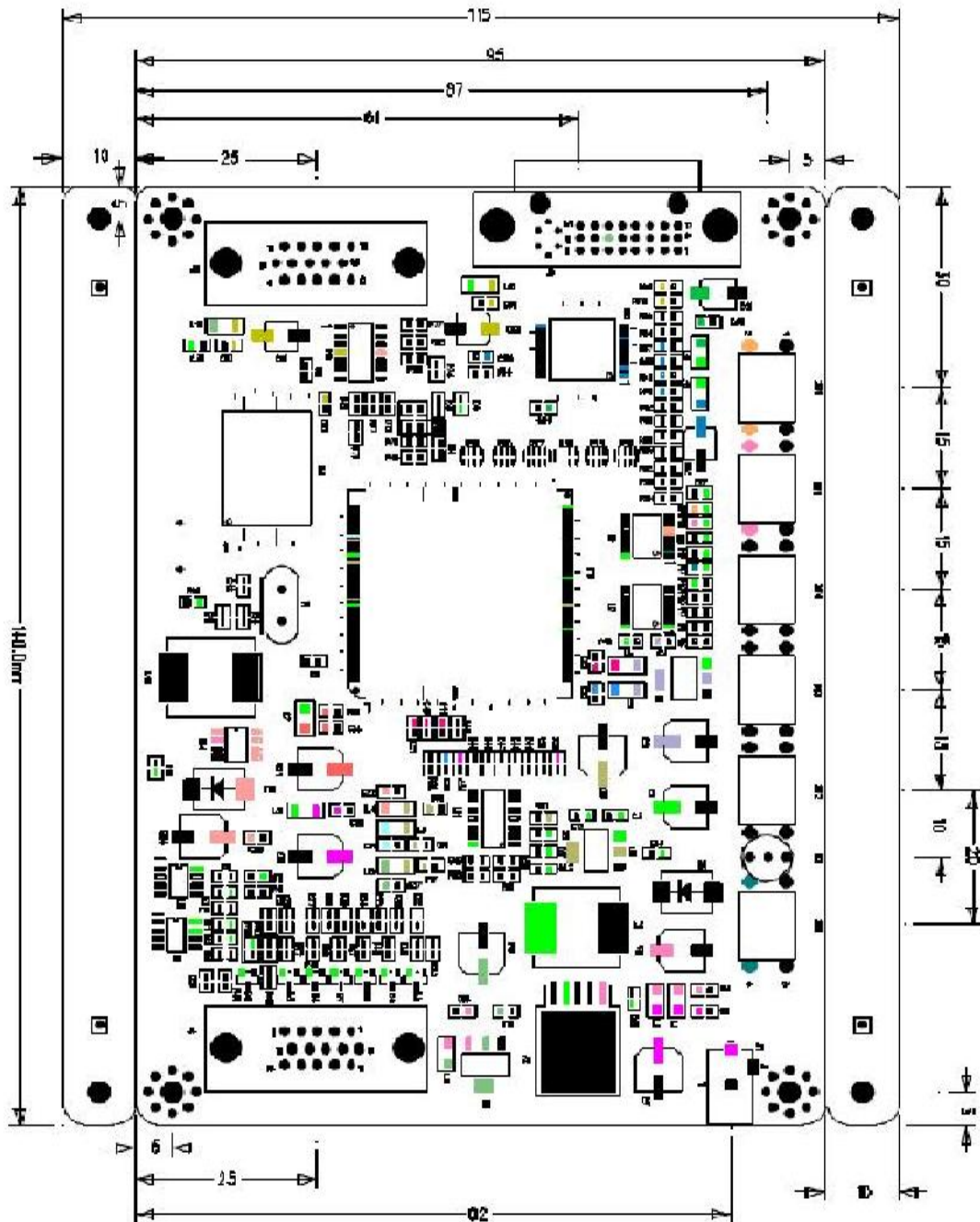

7. Operation Guide

7.1 Installation

This controller board is designed for high quality RGB, DVI monitor.

This section provides some guidelines for assembly and preparation of a finished display solution.

Before proceeding, it is important to familiarize yourself with the parts making up a system and the various connectors, mounting holes and general layout of the controller.

Please follow the below procedure.

1) Signal Inputs Connection

Analog input Signal is available.

Please refer to the clause 4.5 Connector Pin Assignment and connect the signal what you want to apply to the controller board.

Especially, the Analog RGB cable may affect the visual characteristics and regulatory emission test. So, a suitably shielded cable should be used.

2) Power Input Connection

Refer to the 4.5 Connector Pin Assignment and connect the power input cable to the controller board.

Every connection is done but you should consider electrical insulation, grounding, EMI shielding and heat & ventilation.

3) Apply Power

Apply power and turn on the monitor and refer to the following clause.

7.2 OSD Adjustment

EG18RT gives various and very easy graphic user interface through Remote Controller.

Alternatively, user can access to the function using the OSD key board.

(Some function may be done with remote controller only.)

Be sure that your system power and LED is turned off before operating key board.

7.2.1 Key Name and Function

Key Name	Description
Power	Turns ON / OFF the system
Menu	Activates the OSD menu or goes to previous menu
Down	Moves the highlight icon Down to the function that user wants
Up	Moves the highlight icon Up to the function that user wants
+ (Right)	-Increases the adjustment of the selected function -Moves the highlight icon Right to the function that user wants
- (Left)	-Decreases the adjustment of the selected function -Moves the highlight icon Left to the function that user wants

* Press + & - button to select the auto adjustment function *

Accessing the menu system

1. With the OSD off, push the **Menu** button to activate the main OSD menu.
2. Use the **Down** or **Up** buttons to move from one function to another.
As you move from one icon to another, the function name changes to reflect the function or group of functions represented by that icon.
Please refer to the following clause on the next page to view a complete list of all of the functions available for the driver board.
3. Use the **+** or **-** buttons to select the function.
4. After selecting a function, use the **-** or **+** buttons to make optimum adjustments.
The setting bar moves and the numeric value indicator changes to reflect your adjustments.

NOTE: The numeric value indicator is provided as a point of reference only and has nothing to do with a real measurement.

5. Press the **Menu** button once to return to the main menu to select another function or press twice to exit from the OSD.

7.2.2 OSD Adjustment

Menus	Sub-menus	Function Descriptions
Picture	Brightness	Adjusts the brightness of video
	Contrast	Adjusts the contrast of video
	H-position	Adjusts the horizontal position of the image
	V-position	Adjusts the vertical position of the image
	Phase	Removes the noises. When phase value is wrong the image has vertical lines especially in 1 dot on and off
	Frequency	Removes the noises. When phase value is wrong the image has horizontal lines especially in 1 dot on and off

Menus	Sub-menus	Function Descriptions
Advanced	Sharpness	Adjusts the sharpness of video image
	Color temp	Changes the richness of color

Menus	Sub-menus	Function Descriptions
Options	Osd H-position	Change osd h-position
	Osd V-position	Change osd v-position
	Language	English, Germany

Menus	Sub-menus	Function Descriptions
Utilities	Osd time out	Indicates time until the OSD Menu will disappear after adjusting the menu
	Osd background	Changes the opaqueness of the background of the OSD
	Reset	Reset the unit to factory outgoing status

8. Standard Timing Chart

Resolution Timing Item	720 x 400 @70HZ	640 x 480 @60HZ	640 x 480 @75HZ	800 x 600 @60HZ	800 x 600 @75HZ
Pixel Clock(MHZ)	28.324	25.175	31.500	40.000	49.500
Sync Polarity(H/V)	N/P	N/N	N/N	P/P	P/P
Scanning Type	Progressive	Progressive	Progressive	Progressive	Progressive
- H-Frequency(Khz)	31.469	31.469	37.500	37.879	46.875
- Period(us)	31.780	31.778	26.667	26.400	21.333
- Active time(us)	25.420	25.422	20.317	20.000	16.162
- Front porch(us)	0.640	0.636	0.508	1.000	0.323
- Sync width(us)	3.810	3.813	2.032	3.200	1.616
- Back porch(us)	1.906	1.907	3.810	2.200	3.232
- V-Frequency(Hz)	70.082	59.940	75.000	60.317	75.000
- Period(ms)	14.270	16.683	13.333	16.579	13.333
- Active time(ms)	12.710	15.253	12.800	15.840	12.800
- Front porch(ms)	0.413	0.064	0.027	0.026	0.021
- Sync width(ms)	0.064	0.064	0.080	0.106	0.064
- Back porch(ms)	1.080	0.794	0.427	0.626	0.448

Resolution Timing Item	1024 x 768 @60HZ	1024 x 768 @75HZ	1280 x 1024 @60HZ
Pixel Clock(MHZ)	65.000	78.750	108.50
Sync Polarity(H/V)	N/N	P/P	P/P
Scanning Type	Progressive	Progressive	Progressive
- H-Frequency(Khz)	48.363	60.023	63.974
- Period(us)	20.677	16.660	15.631
- Active time(us)	15.754	13.003	11.797
- Front porch(us)	0.369	0.203	0.590
- Sync width(us)	2.092	1.219	1.180
- Back porch(us)	2.462	2.235	2.065

- V-Frequency(Hz)	60.004	75.029	60.013
- Period(ms)	16.666	13.328	16.663
- Active time(ms)	15.880	12.795	16.006
- Front porch(ms)	0.062	0.017	0.016
- Sync width(ms)	0.124	0.050	0.047
- Back porch(ms)	0.600	0.466	0.594

WARRANTY

Dtrovision LLC warrants that each PureLink Product is free from defects due to faulty materials or improper workmanship for a period of one(1) year. Dtrovision LLC further warrants that any part which proves defective in materials or workmanship within one(1) year, will be replaced or repaired at no cost to the user. Labor to replace defective parts will be done without charge. Provided the equipment is returned to Dtrovision LLC prepaid, Insured and properly packaged. Prior return authorization must be obtained from your local dealer.

This warranty is void if the warranted part has been altered or subjected to abuse or misuse.

This warranty is in lieu of all other warranties expressed or implied including, without limitation, any implied warranty or any implied warranty of fitness for a particular purpose. Dtrovision LLC shall have the final right to determination as to the existence and cause of any defect and its appropriate adjustment in accordance with the terms of this warranty. In no event shall Dtrovision LLC be liable for any consequential or collateral damages.

RETURNS

All returns **MUST** have an Return Authorization number. Please contact your local dealer or distributor where you purchased this product to obtain the Return Authorization number.

MEMO
